

ZRC-00MI

For use with models : ZMI-M90Bx, ZMI-M90Cx

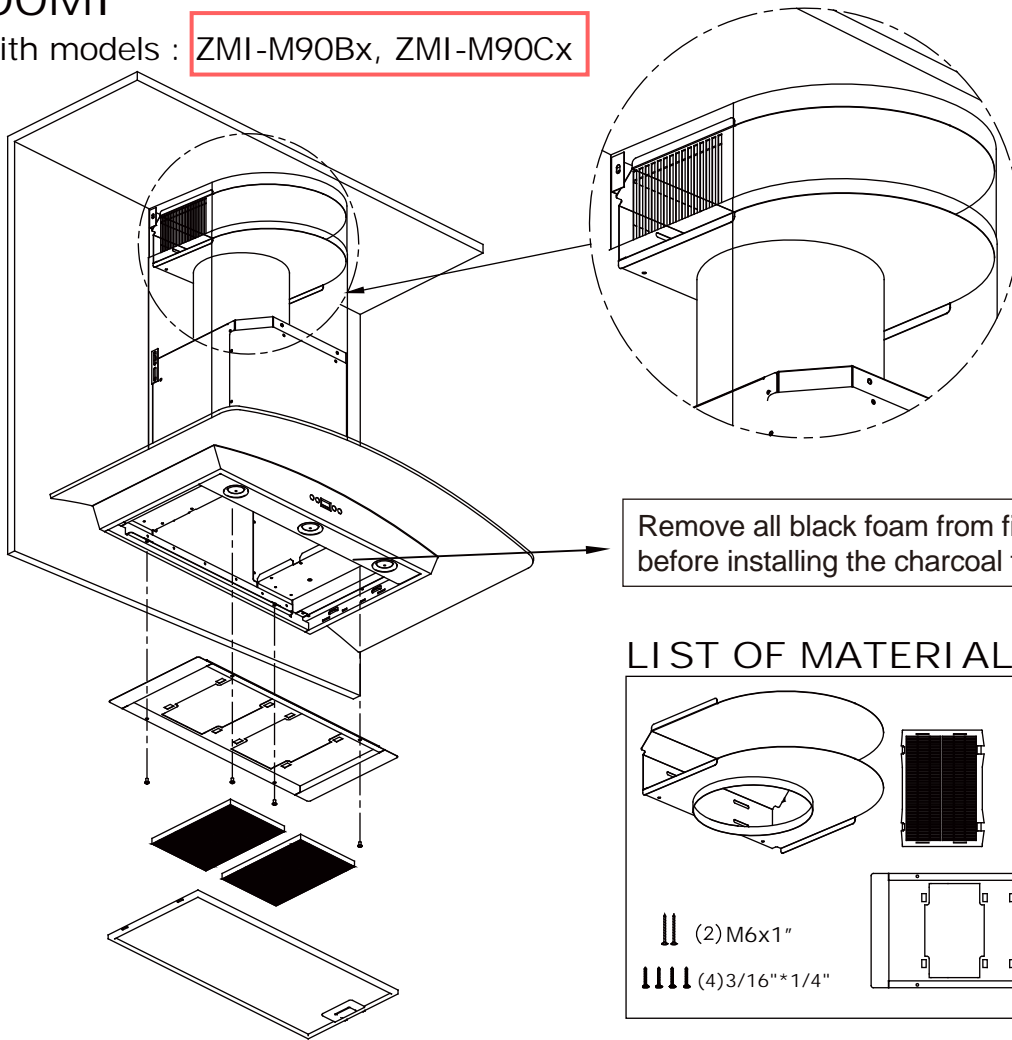

Remove all black foam from filter opening before installing the charcoal filter brackets.

LIST OF MATERIALS

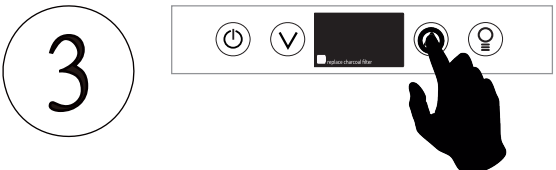
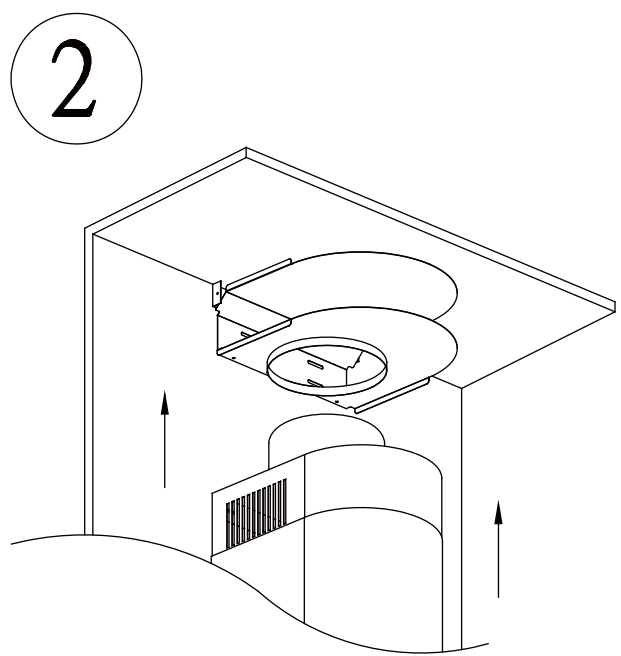
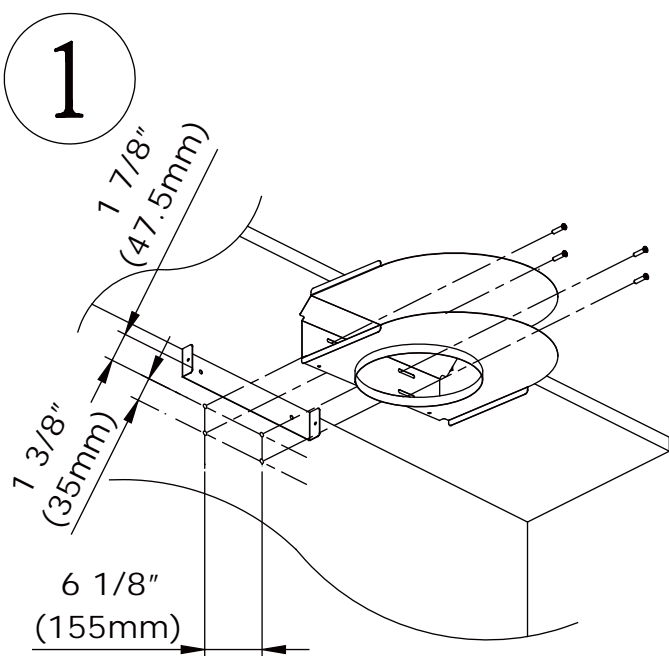
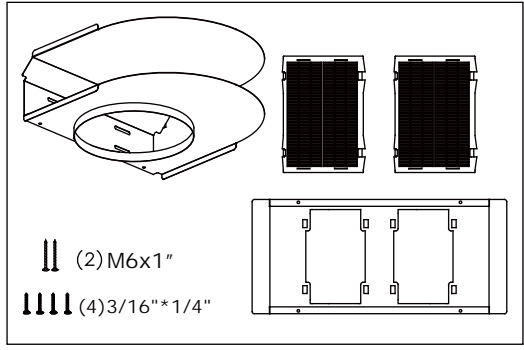

Follow instructions in hood manual to enable the "replace charcoal filter" indicator on the hood controls.