

PRKNCK-001 Presrv™ Kegerator Nitrogen Conversion Kit

The PRKNCK-001 Presrv™ kegerator nitrogen conversion kit allows you to replace your regular tap faucet with a stout faucet, enabling nitrogen dispensing capabilities for beverages such as stout beers and cold brew coffees. PRKNCK-001 is compatible Zephyr PRKFK tap kits for use with Zephyr kegerators.

Keg coupler designs vary based on the beverage being dispensed, see instructions included with your coupler or keg for more details. For more installation and calibration information, refer to the kegerator manual.

List of Materials

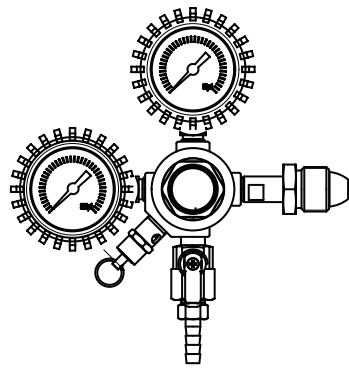

Nitrogen Regulator

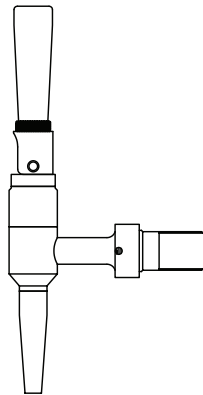

304 Stainless Steel Stout Faucet

NOTE: The keg coupler, nitrogen tank, and hoses are not included in the PRKNCK-001 Presrv™ kegerator nitrogen conversion kit.

Product Specifications

Parts Identification

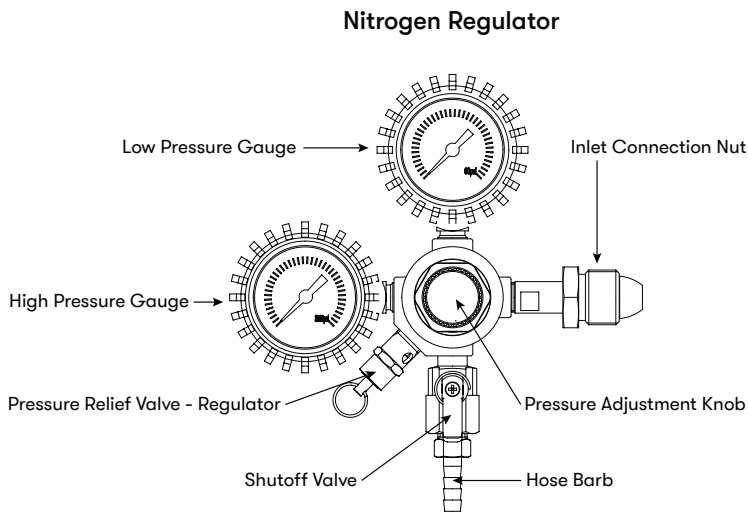

Stout Faucet

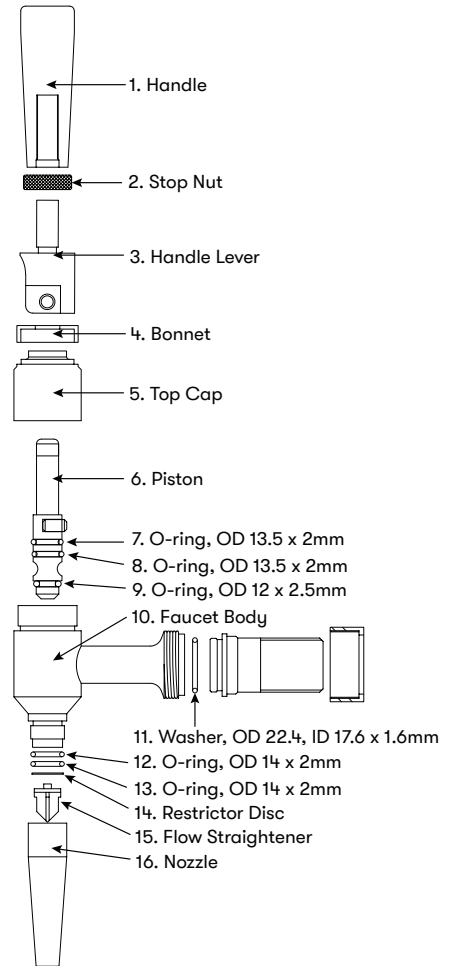

Nitrogen Tank

Zephyr kegerators can accommodate standard nitrogen tanks up to 33 cu.ft. Please contact your nearest welding supply store for nitrogen tanks and for refilling your tank.

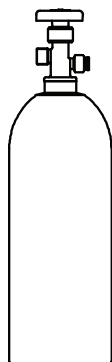

Hardware Package

If a component in the stout faucet is damaged, the replacement parts hardware package, part number 05000199, has the necessary parts for repair. Below are the list of components.

Part Description	Quantity	Ref. #
O-ring, OD 13.5 x 2mm	2	7-8
O-ring, OD 12 x 2.5mm	1	9
Washer, OD 22.4, ID 17.6 x 1.6mm	1	11
O-ring, OD 14 x 2mm	2	12-13
Restrictor Disc	1	14
Flow Straightener	1	15

Installing the Nitrogen Conversion Kit

Refer to the installation manual for your product and read all warnings prior to installing the nitrogen conversion kit. To install the nitrogen conversion kit, please follow the instructions below. This kit is compatible with the single tap kit (PRKFK-01SSC) and can accommodate up to the double tap kit (PRKFK-02SSC) in available kegerator space. Refer to the installation manual of your specific model for tap kit installation and built-in instructions.

1. Attach the 304 stainless steel stout faucet to the tap tower as shown in FIG. A. If a spring is present in the tower shank, it needs to be removed before installing the stout faucet. Make sure the tap is aligned properly and turn the nut counterclockwise by hand. Fully tighten using a beer faucet wrench (provided in Zephyr tap kit accessories).
2. Screw the handle onto the stout faucet shown in FIG. B.

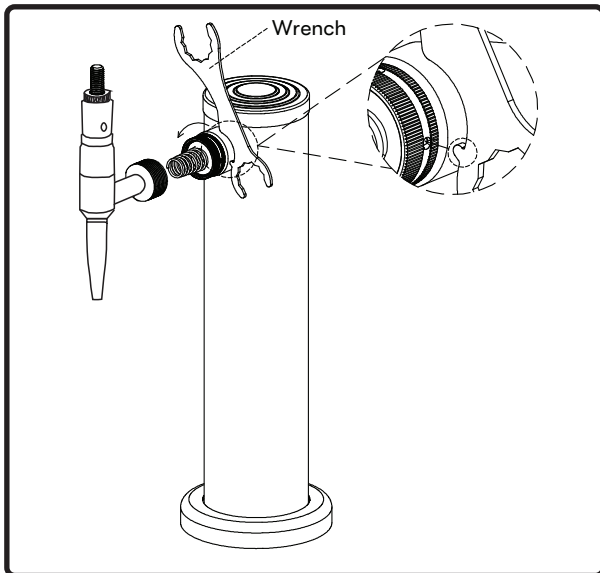

FIG. A

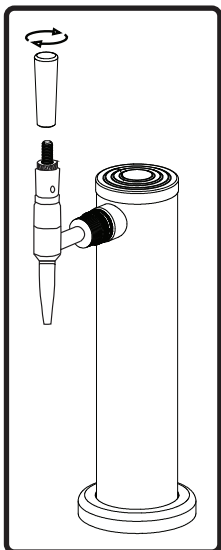

FIG. B

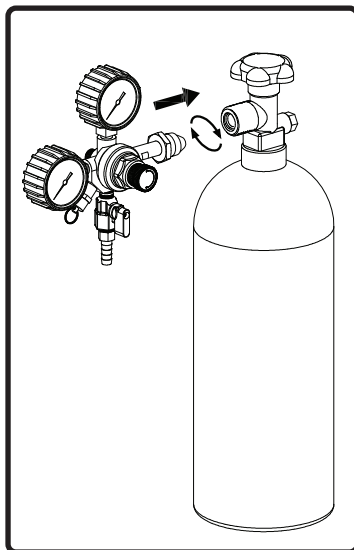

FIG. C

NOTE: Faucet handles use a standard 3/8"-16 UNC thread to accommodate aftermarket handles.

3. Ensure the hand valve on the nitrogen tank is closed. Attach the regulator to the filled nitrogen tank and hand tighten the inlet connection nut (FIG. C). Use a wrench for an additional quarter turn, making sure to not overtighten the nut.
4. Attach the gas line to the hose barb on the regulator shown in FIG. D. Secure using the included metal clamp and tighten using a flathead screwdriver. Attach other end of the gas line to the keg coupler.
5. Connect beer/beverage lines from tap tower to the keg coupler.
6. Check for gas leaks. Mix a solution of dish soap with water in a spray bottle. Generously spray all the connections of the suspected leak zone included all threaded connections and lines.

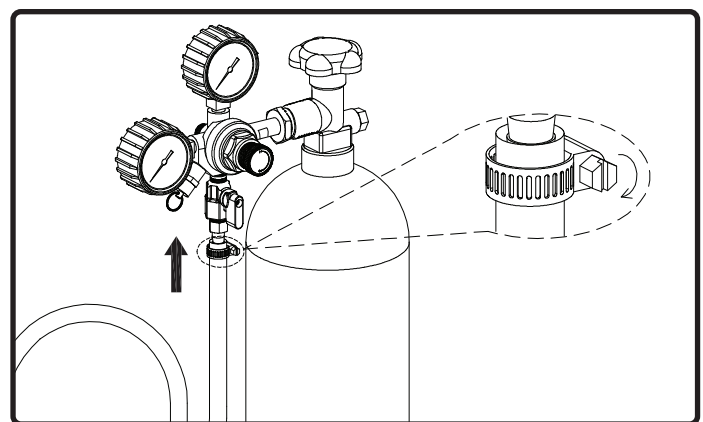

FIG. D

Care and Maintenance

Cleaning Components Exposed to Beer

Frequent cleaning of components that are often exposed to beer will prevent bad tasting beer caused by buildup of deposits and bacteria. Cleaning these components will remove beer residue from from the stout faucet and beer lines, keeping your beer tasting fresh.

We recommend using the Zephyr Kegeator Beer Line Cleaning Kit, PRKCLN-001, to clean your beer lines and faucet every 6 weeks or each time the beer keg is replaced to maintain fresh tasting beer.

Over time, a deep cleaning of the beer lines and faucet are required due to buildup. Please follow the instructions below for thoroughly cleaning those components.

1. Close the nitrogen hand valve and remove all pressure with the pressure relief valve.
2. Disengage the keg coupler. Remove the gas line and beer line. Handle with care to prevent spilling of residual beer.
3. Remove the stout faucet from the tap tower using the included wrench. Unscrew the stout nozzle taking care to not misplace the restrictor disc, flow straightener, or o-rings.
4. Soak the keg coupler and stout faucet in warm water with some beer line cleaning solution for 30 minutes.
5. For additional cleaning, use a spout brush to remove any residual debris or buildup from the stout faucet.
6. Rinse and reassemble everything once cleaned.

Possible Problem	Possible Cause	Solutions
The beverage is foamy upon pouring.	The tap handle is not being fully pulled.	Fully pull back on the tap handle.
	The beverage is warm.	Allow the kegs to sit in the kegerator for at least 24 hours to allow gases to absorb into the beverage.
	There is excessive nitrogen pressure.	Lower and adjust the nitrogen pressure to between 30-40 PSI.
	The tap lines are old.	Either replace or clean the tap lines.
	The stout faucet is clogged.	Clean the stout faucet.
	Using a CO ₂ tank for the stout faucet.	Replace CO ₂ tank with a nitrogen tank.
The beverage is flat upon pouring.	The tap handle is not being fully pulled.	Fully pull back on the tap handle.
	The glasses that the beverage is being poured into are greasy.	Wash the glasses thoroughly after each use and allow to air dry. Do not dry wipe.
	There is not enough nitrogen pressure.	Refill the nitrogen tank if empty. Check the nitrogen tank valve, making sure it is open. Check for obstructions in the gas lines. Check the shutoff valve from the regulator, making sure it is fully open. If the PSI is too low, raise the nitrogen pressure to between 30-40 PSI.
	Gas leakage preventing adequate pressure.	Mix a solution of dish soap with water in a spray bottle. Spray all the connections of the suspected leak zone included all threaded connections and lines. Inspect and repair area.
	The beverage is not cold enough.	Allow the kegs to sit in the kegerator for at least 24 hours to allow gases to absorb into the beverage.
	There is too much oxygen in the keg, preventing nitrogenation.	Purge the keg by setting the regulator to around 10 PSI, pull the pressure relief valve on the keg a few times to purge out the oxygen.
The beverage is bad or off-tasting.	The tap lines or stout faucet is dirty.	Clean the tap lines and stout faucet with the beer line cleaning kit, PRKCLN-001.
	The gas lines are dirty.	Replace the gas lines if they appear contaminated.
	The beverage is old.	Replace the keg with the fresh beverage.

Troubleshooting

Possible Problem	Possible Cause	Solutions
The beverage does not have a cascading effect.	There is insufficient nitrogenation.	Allow the kegs to sit in the kegerator for at least 24 hours to allow gases to absorb into the beverage and dispense at an appropriate PSI (30-40 PSI).
	Improper pouring technique.	Hold the glass at an angle and pour down the side of the glass to minimize agitation.
	The stout faucet is clogged.	Clean the beer line and stout faucet with the beer line cleaning kit, PRKCLN-001.
The cold brew coffee tastes harsh and sharp.	Using beer gas instead of pure nitrogen. CO ₂ permeates the liquid, altering the taste and mouthfeel over time.	Beer gas is typically a 75% nitrogen, 25% CO ₂ blend. Request for pure nitrogen at a local welding supply store.
	The cold brew coffee exposed to oxygen for prolonged periods.	Replace the beverage. Purge the keg by setting the regulator to around 10 PSI, pull the pressure relief valve on the keg a few times to purge out the oxygen.

Zephyr Ventilation, LLC (referred to herein as “we” or “us”) warrants to the original consumer purchaser (referred to herein as “you” or “your”) of Zephyr products (the “Products”) that such Products will be free from defects in materials or workmanship as follows:

Two Year Limited Warranty for Parts: For two years from the date of your original purchase of the Products, we will provide, free of charge, Products or parts to replace those that failed due to manufacturing defects subject to the exclusions and limitations below. We may choose, in our sole discretion, to repair or replace parts before we elect to replace the Products.

To Obtain Service Under Limited Warranty: To qualify for warranty service, you must: (a) notify us at www.zephyronline.com/contact within 60 days of discovering the defect; (b) give the model number and serial number (if applicable); and (c) describe the nature of any defect in the Product or part. At the time of the request for warranty service, you must present evidence of your proof of purchase and proof of the original purchase date. If we determine that the warranty exclusions listed above apply or if you fail to provide the necessary documentation to obtain service, you will be responsible for all shipping and other costs related to the services. This warranty is not extended or restarted upon warranty repair or replacements.

Warranty Exclusions: This warranty covers only repair or replacement, at our option, of defective Products or parts and does not cover any other costs related to the Products including but not limited to: (a) normal maintenance and service required for the Products and consumable parts such as gaskets, filters, light bulbs, fuses; (b) any Products or parts which have been subject to freight damage, misuse, negligence, accident, faulty installation or installation contrary to recommended installation instructions, improper maintenance or repair (other than by us); (c) commercial or government use of the Products or use otherwise inconsistent with its intended purpose; (d) natural wear of the finish of the Products or wear caused by improper maintenance, use of corrosive and abrasive cleaning products, pads, and oven cleaner products; (e) chips, dents or cracks caused by abuse or misuse of the Products; (f) service trips to your home to teach you how to use the Products; (g) damage to the Products caused by accident, fire, floods, acts of God; or (h) Custom installations or

alterations that impact serviceability of the Products. (l) Damage to personal property or food spoilage from use of this product. If you are outside our service area, additional charges may apply for shipping costs for warranty repair at our designated service locations and for the travel cost to have a service technician come to your home to repair, remove or reinstall the Products. All Products must be installed by a qualified professional installer to be eligible for warranty repairs or service.

Limitations of Warranty: OUR OBLIGATION TO REPAIR OR REPLACE, AT OUR OPTION, SHALL BE YOUR SOLE AND EXCLUSIVE REMEDY UNDER THIS WARRANTY. WE SHALL NOT BE LIABLE FOR INCIDENTAL, CONSEQUENTIAL OR SPECIAL DAMAGES ARISING OUT OF OR IN CONNECTION WITH THE USE OR PERFORMANCE OF THE PRODUCTS. THE EXPRESS WARRANTIES IN THE PRECEDING SECTION ARE EXCLUSIVE AND IN LIEU OF ALL OTHER EXPRESS WARRANTIES. WE HEREBY DISCLAIM AND EXCLUDE ALL OTHER EXPRESS WARRANTIES FOR THE PRODUCTS, AND DISCLAIM AND EXCLUDE ALL WARRANTIES IMPLIED BY LAW, INCLUDING THOSE OF MERCHANTABILITY AND FITNESS FOR A PARTICULAR PURPOSE.

Some states or provinces do not allow limitations on the duration of an implied warranty or the exclusion or limitation of incidental or consequential damages, so the above limitations or exclusions may not apply to you. To the extent that applicable law prohibits the exclusion of implied warranties, the duration of any applicable implied warranty is limited to the same two-year and one-year periods described above if permitted by applicable law. Any oral or written description of the Products is for the sole purpose of identifying the Products and shall not be construed as an express warranty. Prior to using, implementing or permitting use of the Products, you shall determine the suitability of the Products for the intended use, and you shall assume all risk and liability whatsoever in connection with such determination. We reserve the right to use functionally equivalent refurbished or reconditioned parts or Products as warranty replacements or as part of warranty service. This warranty is not transferable from the original purchaser and only applies to the consumer residence where the Product was originally installed located in the United States and Canada. This warranty is not extended to resellers.

Please check our website for any additional Product information, www.zephyronline.com.
For warranty support, contact us at www.zephyronline.com/contact.

Zephyr Ventilation Service Department, 2277 Harbor Bay Parkway, Alameda, CA 94502