

# ZMI-M90BG ZMI-M90BS

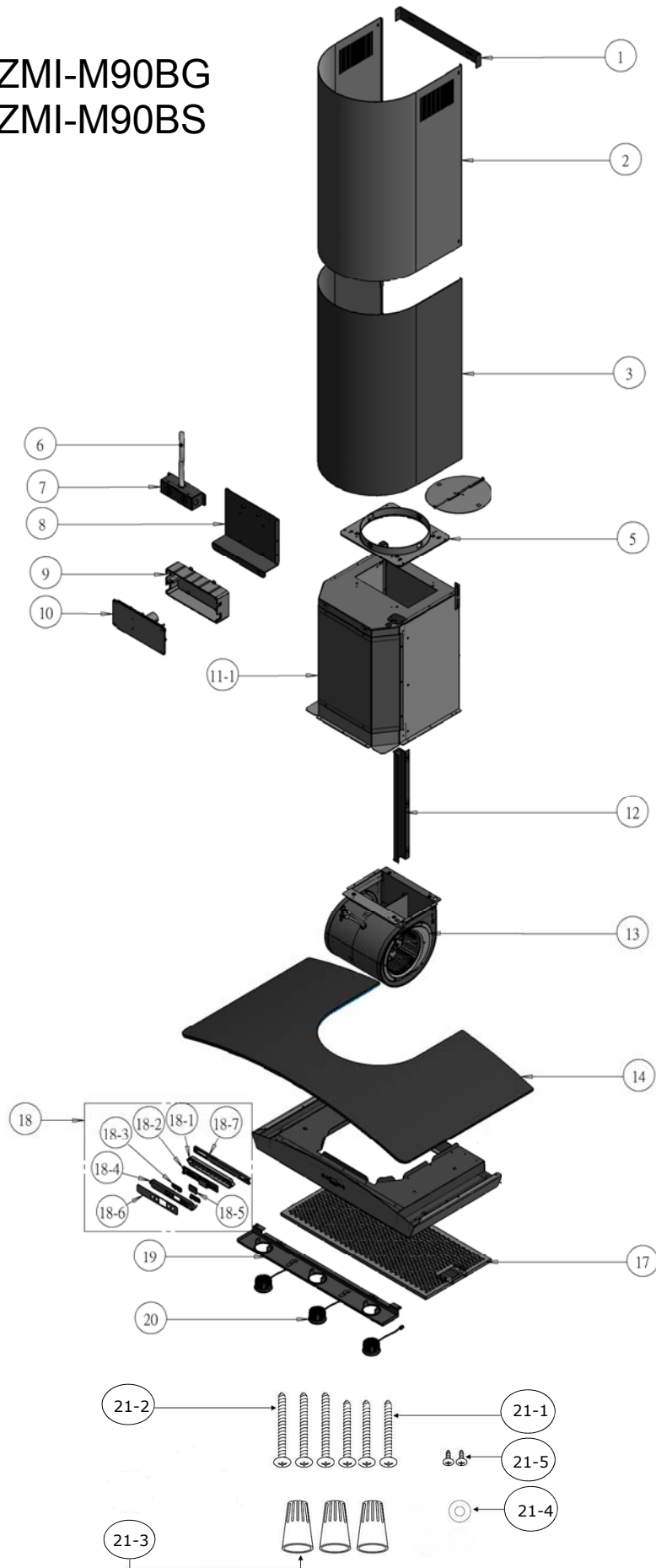

**ZEPHYR**

# Milano Wall

**ZMI-M90BG, ZMI-M90BS**

Ref #	Part #	Description	Qty.
1	54110079	Bracket, Duct Cover	1
2	50050124	Duct Cover, Upper	1
3	50050125	Duct Cover, Lower	1
5	54050080	Collar, 8" round w/damper	1
6	11030070	Wires, Electrical	1
7	50500085	Assembly, Electrical Box	1
8	54140115	Bracket, Electrical	1
9	56200051	Box, Component	1
10	11010043	Control Board (SN <24)	1
10	11010051	Control Board (SN 24+)	1
11-1	54210007	Cover, Motor Housing	1
12	54140116	Bracket, Component Wire	1
13	12120064	Motor	1
14	50300098	Canopy, Glass (ZMI-M90BG)	1
14	50300099	Canopy, Stainless (ZMI-M90BS)	1
17	50200044	Filter, Aluminum Mesh	1
18	11000071	Switch Assembly	1
18-1	52170042	Housing, Switch	1
18-2	11010044	Switch Board	1
18-3	50400011	Button, Switch	2
18-4	56210055	Cover, Switch	1
18-5	52170043	Cover, LCD Screen	1
18-6	54140117	Bracket, Switch, Front	1
18-7	54140118	Bracket, Switch, Rear	1
19	50110097	Panel, Light (SN <24)	1
19	50110149	Panel, Light (SN 24+)	1
20	Z0B0062	Bulb, LED, 3W (SN <24)	3
20	Z0B0064	Bulb, LED, 6W (SN 24+)	2
21	05000079	Hardware Packet	1
21-1	01090001	Screw, M6 x 1"	3
21-2	01090002	Screw, M6 x 1 1/2"	3
21-3	15000002	Wire Nut	3
21-4	02170001	Washer	1
21-5	01060004	Screw, M3 x 8mm	2